

F5 SYSTEM





DIVERSITY.
COLOUR.
INSPIRATION.

F5 SYSTEM

ABOUT

The F5 system is the solution for the offices seeking greater diversity, colour and inspiration. The desk mounted system embodies a timeless design and provides multiple options to the workplace as they are easily reconfigured and are a great cost effective option for any context.

Recyclable and re-usable properties ensures the F5 is environmentally friendly, while also delivery core elements of strength and stability.

FEATURES Pg 6

ACCESSORIES Pg 7-9

CONFIGURATIONS Pg 10



FEATURES

OPTIONS

- Desk mounted or in-desk units available including soft wiring
- Optional power and data above or below desk includes soft wiring
- Cable trays
- Two tiered cable baskets
- Umbilical cords

ACCESSORIES

- Whiteboard
- Document trays
- Pens Holder
- Desk mounted shelf
- Mobile Pedestals & Caddies
- Monitor arms

LEG SYSTEMS

- Delta 'O'
- Delta 'U'
- Delta 'A'
- Delta Timber

FINISHES

- Fabric
- Acrylic
- Echo Panel (pin board)

ACCREDITATIONS

- 10 Year Warranty
- AFRDI & GECA approved
- 3 – 4 Week Lead Time



ACCESSORIES



DESK MOUNTED SHELF



WHITE BOARD



FUNCTION BOARD

ACCESSORIES



▶ MOBILE PHONE TRAY



▶ PIXEL



▶ SCREEN TRAY

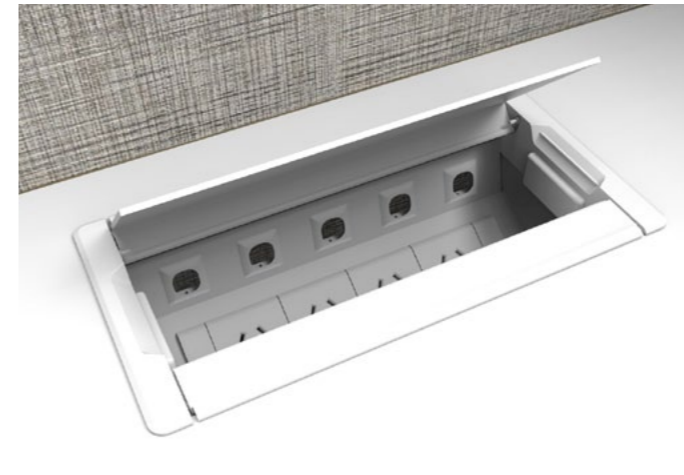

▶ IN DESK BOX



▶ PENCIL HOLDER

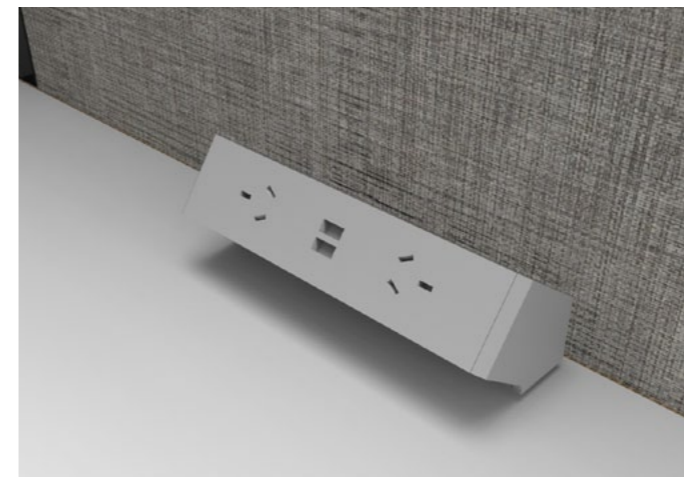

▶ POWER RAIL

CONFIGURATIONS

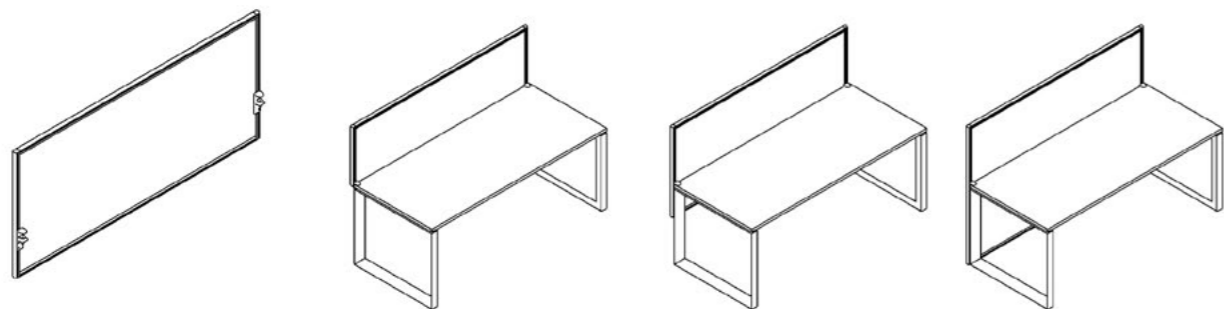

SCREEN FRAME / PANELS

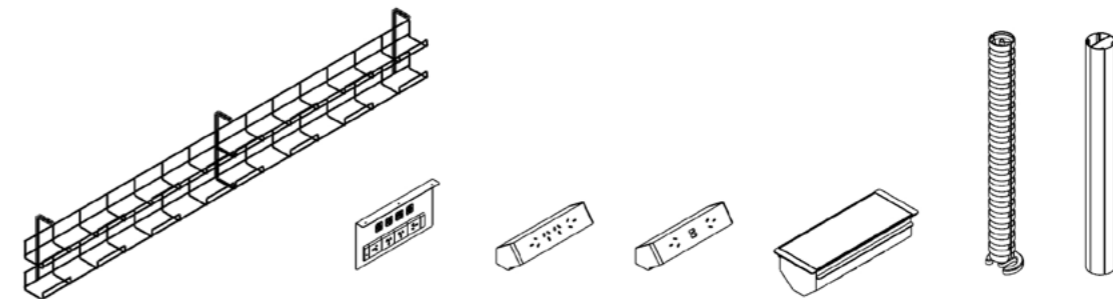

CABLE MANAGEMENT - POWER AND DATA

The F5 Screen System does not include in-screen integrated power and data but does accommodate segregated cable baskets, soft wiring, power + data/usb modules, power + data rails, power + data service boxes, umbilicals and power poles

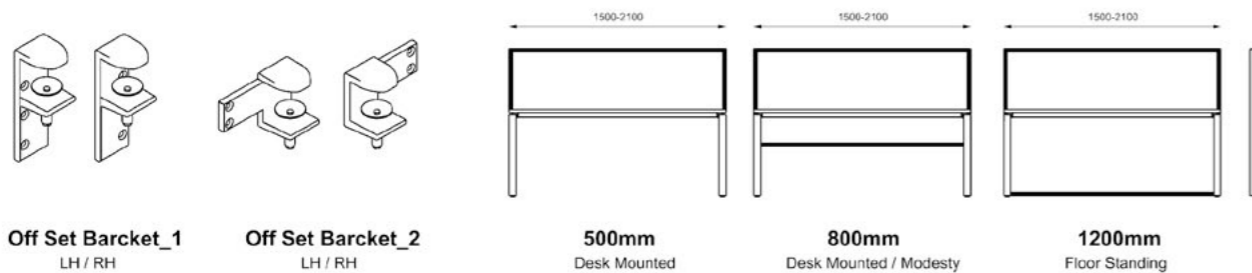

Off Set Bracket_1
LH / RH

Off Set Bracket_2
LH / RH

500mm
Desk Mounted

800mm
Desk Mounted / Modesty

1200mm
Floor Standing

WORKSTATION SUPPORT BRACKETS

WORKSTATION SCREEN HEIGHTS Standard heights shown - other options available

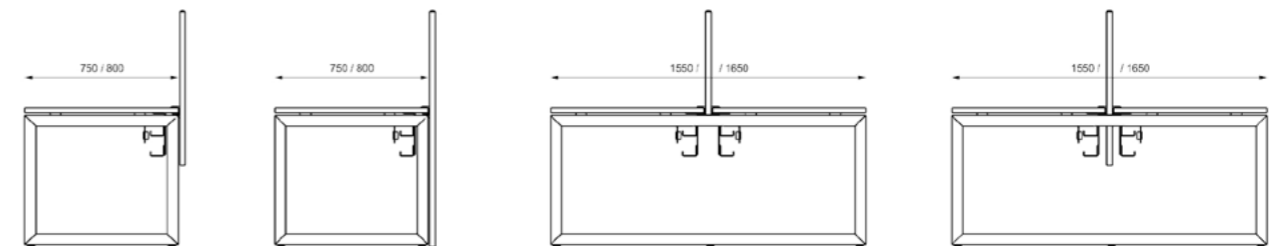

CABLE MANAGEMENT - SCREEN ORIENTATION

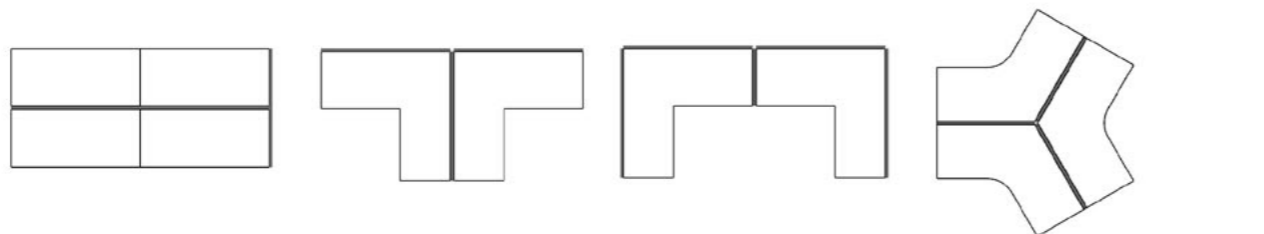

TYPICAL WORKSTATION CONFIGURATIONS FOR F5 SYSTEM

Configuration examples shown with various shape workstations

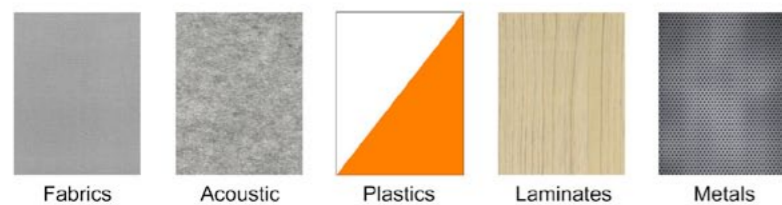

PANEL FINISHES

The F5 Screen System can accommodate various paneling materials (total 12mm). These include pinnable board, fabric wrapped panels, acoustic panels, acrylic sheets and metals

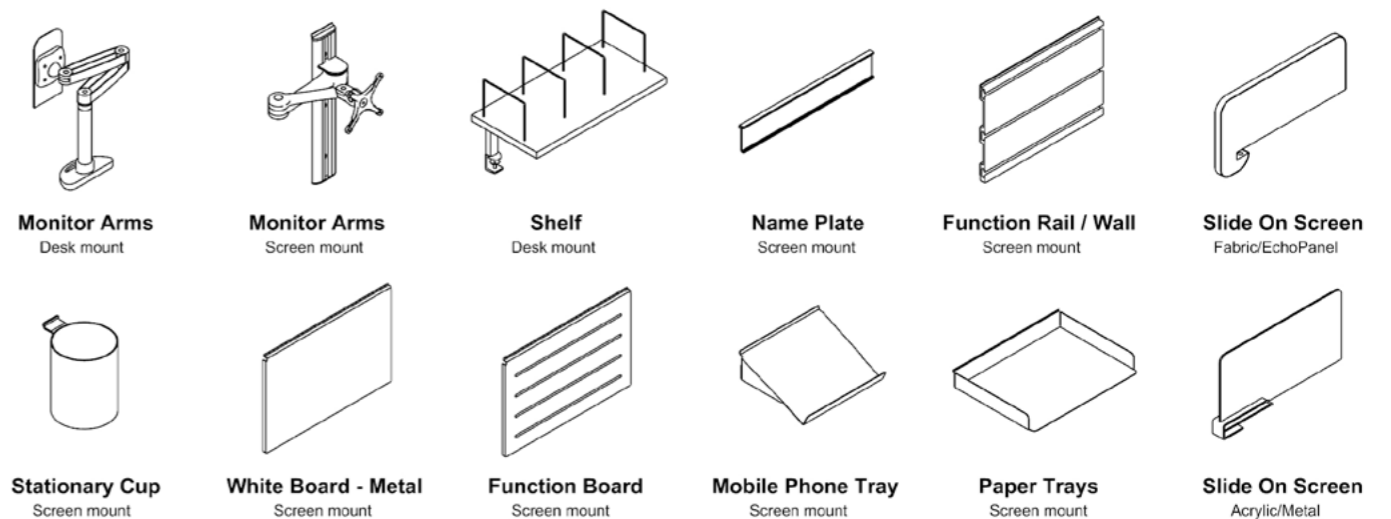

Monitor Arms
Desk mount

Monitor Arms
Screen mount

Shelf
Desk mount

Name Plate
Screen mount

Function Rail / Wall
Screen mount

Slide On Screen
Fabric/EchoPanel

Stationary Cup
Screen mount

White Board - Metal
Screen mount

Function Board
Screen mount

Mobile Phone Tray
Screen mount

Paper Trays
Screen mount

Slide On Screen
Acrylic/Metal



LIMITLESS
CONFIGURATIONS.
COST EFFECTIVE.

