

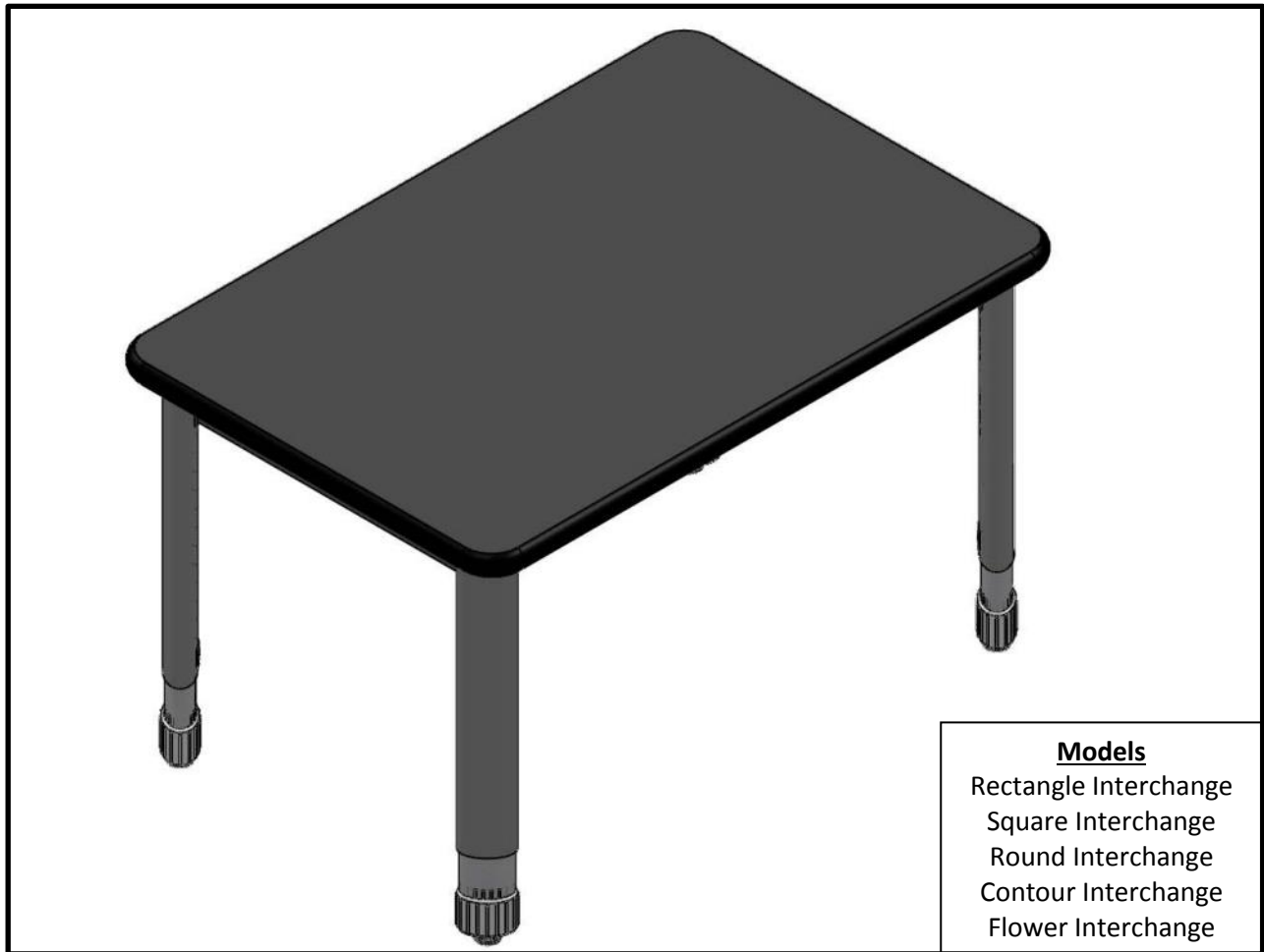

Smith System®

Interchange Activity Table Assembly Instructions



For Assistance in assembling product, missing or damaged parts,
or to place an order, please contact customer service at 800-328-1061
You may also place your order online at
www.smithsystem.com

Hardware and Components

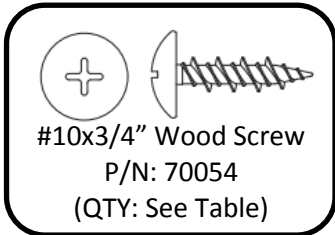
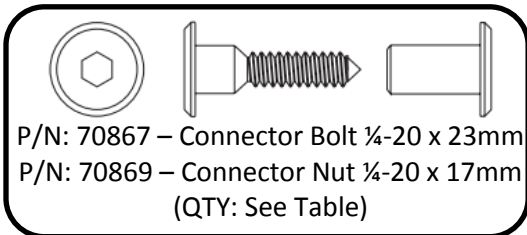
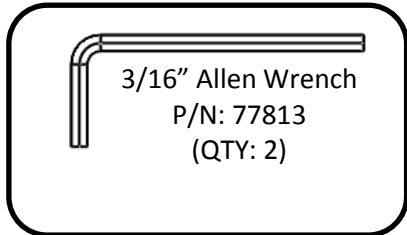
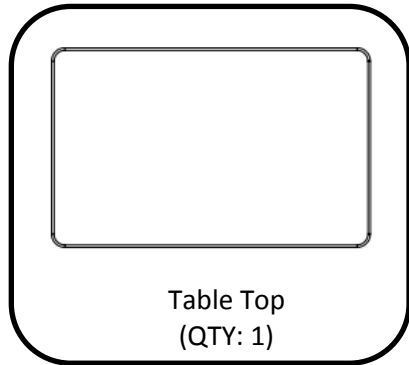
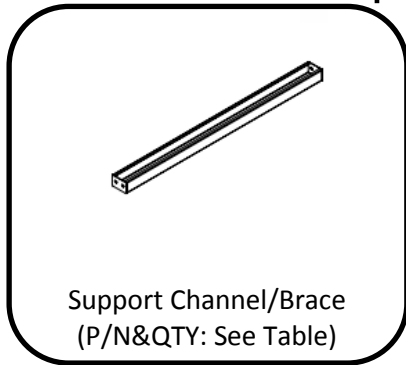
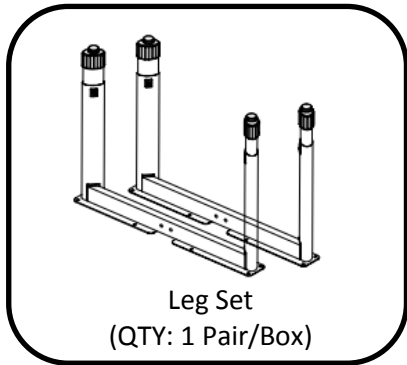

MODEL	LEG SET	BRACE	BRACE QTY	HARDWARE PACK	TOP SIZE
04100	79804	77506	1	67607	24X36
04101	79804	77508	1	67607	24X48
04102	79804	77509	1	67607	24X60
04103	79804	77510	1	67607	24X72
04104	79804	77511	1	67607	24X90
04105	79805	77506	1	67607	30X36
04106	79805	77508	1	67607	30X48
04107	79805	77509	1	67607	30X60
04108	79805	77510	1	67607	30X72
04109	79805	77511	1	67607	30X90
04110	79806	77506	1	67607	36X36
04111	79806	77508	1	67607	36X48
04112	79806	77509	1	67607	36X60
04113	79806	77510	1	67607	36X72
04114	79806	77511	1	67607	36X90
04115	79807	77507	2	67608	42X42
04116	79807	77509	2	67608	42X60
04117	79807	77510	2	67608	42X72
04118	79807	77511	2	67608	42X90
04119	79808	77508	2	67608	48X48
04121	79808	77509	2	67608	48X60
04122	79808	77510	2	67608	48X72
04123	79808	77511	2	67608	48X90
04124	79805	77505	1	67607	42 DIA.
04125	79805	77506	1	67607	48 DIA.
04126	79806	77508	1	67607	60 DIA.
04129	79508	77508	1	67607	CONTOUR
04132	79806	77508	1	67607	FLOWER

- Replacement Hardware Packs:
1. 67607 – HDWR PK, Inter Act 24, 30, 36
 - a. (2) 77813 – 3/16" Allen Wrench
 - b. (4) 70867 - Connector Bolt ¼-20 x 23mm
 - c. (4) 70869 – Connector Nut ¼-20 x 17mm
 - d. (26) 70054 - #10x3/4" Wood Screw
 2. 67608 – HDWR PK, Inter Act 42, 48
 - a. (2) 77813 – 3/16" Allen Wrench
 - b. (8) 70867 – Connector Bolt ¼-20 x 23mm
 - c. (8) 70869 – Connector Nut ¼-20 x 17mm
 - d. (44) 70054 - #10x3/4" Wood Screw

For Assistance in assembling product, missing or damaged parts,
or to place an order, please contact customer service at 800-328-1061
You may also place your order online at

www.smithsystem.com

Assembly Instructions

Step 1: Place the top on a clean, dry surface laminate side down, so that the predrill holes face up.

Step 2a: Loosely attach the legs to the support brace using (4) connector bolts and (4) connector nuts. (See Picture #1A)

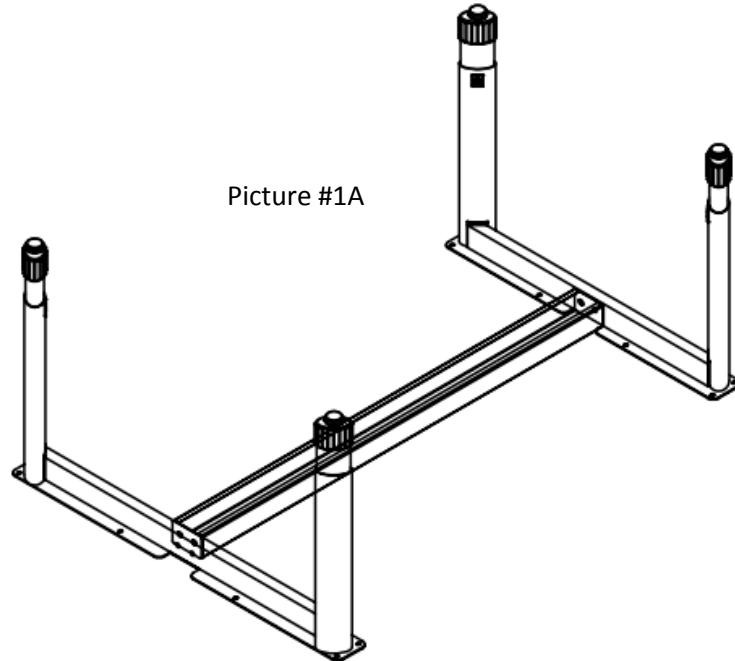

Step 2b: If your table requires a bigger assembly, attach the legs to the braces using (8) Connector Bolts and (8) connector Nuts. (See Picture #1B)

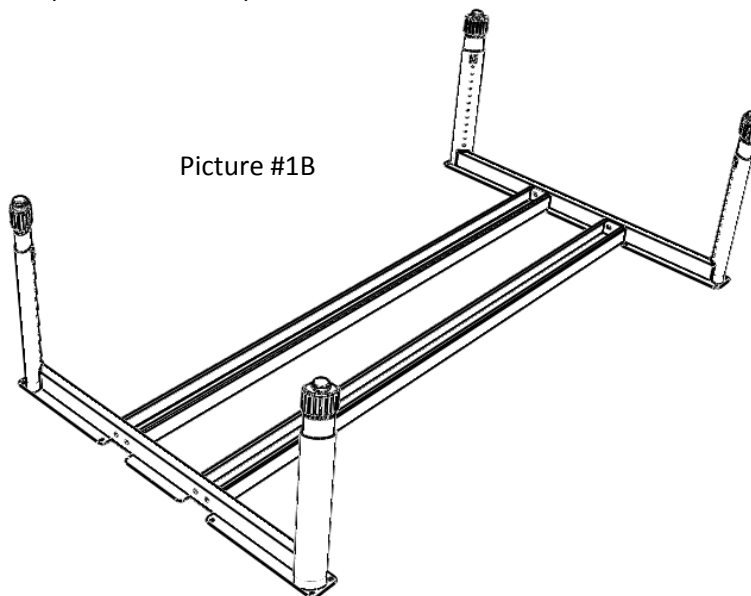

For Assistance in assembling product, missing or damaged parts,
or to place an order, please contact customer service at 800-328-1061
You may also place your order online at
www.smithsystem.com

Step 3: Align the slots of the Leg Assembly to the pre-drilled holes of the top. Using the $\frac{3}{4}$ " screws provided, attach the leg assembly to the top. (Tip: Stagger the screws in the beginning. For example, Fasten one screws on one of the legs, then another screw on the other leg. Continue to stagger the screws until the assembly is attached to the top using all of the screws.

Picture #2

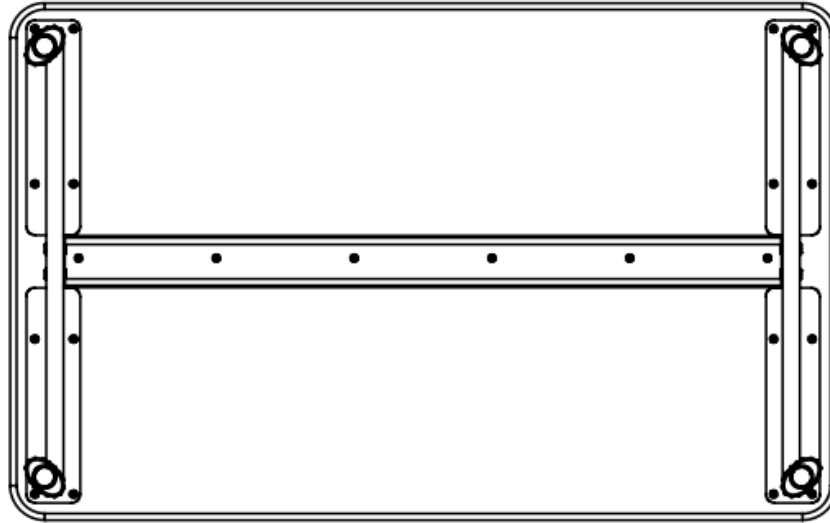

Step 4: Tighten the connector bolts and nuts to the channel, attached in Step 2, using both hex keys provided.

Step 5: Adjust the leg height as needed by loosening the set screw in the leg (use the hex key to loosen). Tighten the set screws. Hand tighten, do not use power tool, to tighten set screw to ensure screw is correctly located in the insert hole.

Picture #3

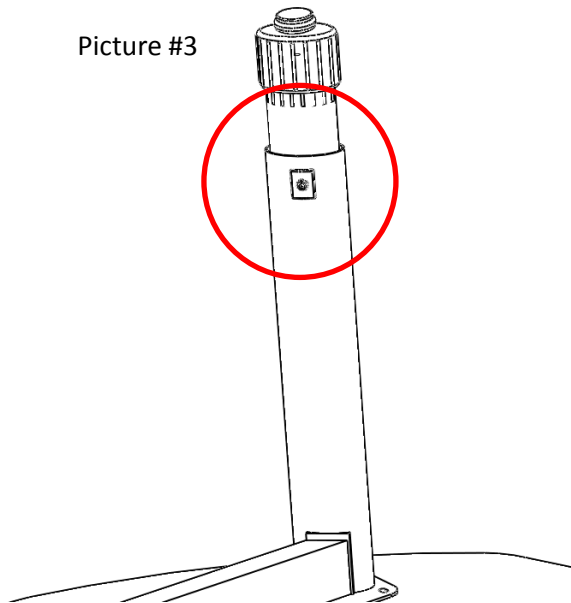

Step 6: Use the help of at least one other person and turn the table over to an upright position.

For Assistance in assembling product, missing or damaged parts,
or to place an order, please contact customer service at 800-328-1061
You may also place your order online at
www.smithsystem.com