

# Opus



v2.0

**+Halle<sup>®</sup>**

## Opus

The Opus collection exists in the vein of the great mid-century classics, a pared-back club chair that uses the bare minimum to create a personal sphere, a neat hybrid system of seats designed by Swedish design studio Form Us With Love in collaboration with Danish design brand +Halle.

‘We asked ourselves: “how do we create a personal space with the smallest means possible?” And we discovered that the challenges we faced were partly due to old proportions. Traditionally—if we are talking sound absorption, isolation, and phone booths—more is more. But in the case of Opus, we stepped away from that mindset, beginning at the other end of the spectra. Together we pinned up a semi-transparent mesh around a structure and then gradually added the least amount of material that the chairs could hold,’ says Martin Halle, Creative Director at +Halle.

‘Over the last three years, we tried and tested the limits of personal space with our design. The experiments were made with 1:1 prototype seats and blinds, aimed for as little interference with the environment as possible. By using a stool as a base, a metal rod and a felt band at the top, we were mimicking the blinkers on a horse. That was our starting point,’ says John Löfgren Creative Director at Form Us With Love and he continues: ‘it became an investigation of the minimum needed for full focus.’

The purpose of Opus was born out of the first Annual Briefing, a behavioural-led design forum held in Stockholm in 2018. In its infancy, the mesh and the blinders certainly felt like a radical take on the traditional category of dwelling. The main potential being softness and craft, in an airy structure. ‘Today, we see a lot of heavy seats trying to provide for privacy, with Opus we are using thin screens and bent steel, striving for lightness,’ Löfgren adds.

Spread across four seats, the series comprises of a dining chair and a lounge chair, which also comes with a high backrest, with or without a table. The idea of using lightweight metal frames to hold the seat and backrest gives you a sense of seclusion yet provides an open interior. We saw the need for a club chair that is easy to place, sturdy, hygienic, with a spacious silhouette and a dwelling quality,’ Löfgren explains.

‘We were wondering, why the category of self-seclusion has not seen a minimum version made yet? Instead, it seems the maximum has been heavily explored. When you start reducing, in the realm of sound-absorbing qualities the category becomes very interesting. I think the industry at large has been ambivalent towards the cry for personal space, which has resulted in thick and bulky solutions, with Opus we are challenging that status quo,’ says Halle.

The ambition is to create a space where you feel both secluded and part of your environment. ‘Throughout the Annual Briefing, we kept asking “how do we stay within the constraints of lightness?” Löfgren recalls. ‘The result is a collection that can be placed in many different rooms thanks to a slimmed frame. We strive for Opus to be transparent and multifunctional, solving challenges of co-habiting interaction and privacy in a dynamic space.’ Halle replies.

Visually the Opus collection is slender, does not overpower and creates a subtle harmony with its surrounding. ‘It’s about reducing material and creating a focus with the least possible. Opus is easy to move around, see-through and create an open interior with,’ Löfgren reflects. ‘The name, Opus, is work-related, but we wanted to give the series lounge qualities too. The experience, of sitting in Opus for a few hours, should not feel less, but sound, sturdy and rich, despite an airy construction, Halle concludes.

### Design: Form Us With Love

Form Us With Love was founded in 2005 and since its conception, the studio has burned with a passion for design and its democratic potential. Its belief is that we all have a right to meaningful design. At the studio’s core lies a process that blends traditional creative practices with a lean, strategic application. The central intention is to evolve with the needs of each project, its place in the market and the ever-changing needs of real people.

## Specifications

Models	Width	Depth	Height	Weight (Net/Gross)	Package dimensions (W / D / H)
Chair	65 cm	53 cm	75 cm	14 kg / 16 kg	67 / 55 / 77 cm
Lounge Chair	81 cm	71 cm	75 cm	21 kg / 23 kg	83 / 73 / 77 cm
High Back Chair	83 cm	72 cm	145 cm	30 kg / 32 kg	85 / 74 / 147 cm
High Back Chair with Table	83 cm	103 cm	145 cm	32 kg / 34 kg	85 / 105 / 147 cm

**Designed by** Form Us With Love

**Material**

Frame:	Steel
Seat / Backrest:	Foam
Screen:	Aluminium, Foam
Table:	Solid oak
Feet:	PA

**Fabrics**

Seat / Backrest:	Available in all fabrics and leather types
Screen:	Gabriel® Hush Stripe 25

**Tests & certificates**

FSC®-163859  
L2: Extreme Use

## Dimensions

Opus Chair

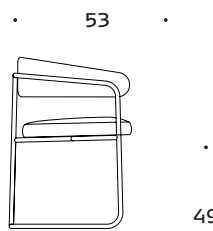
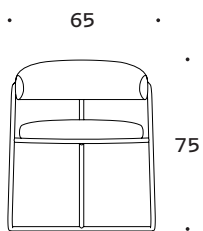

Opus Lounge Chair

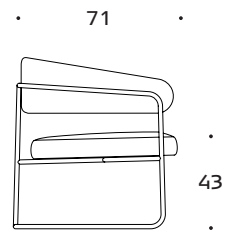
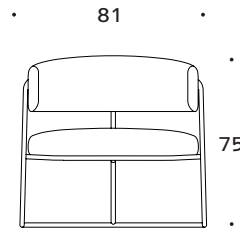

Opus High Back Chair

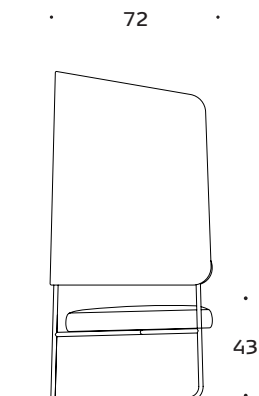
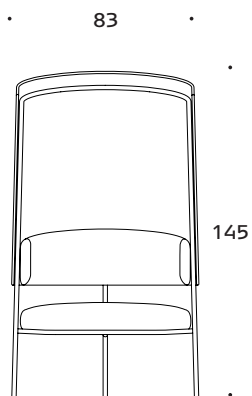

Opus High Back Chair with Table

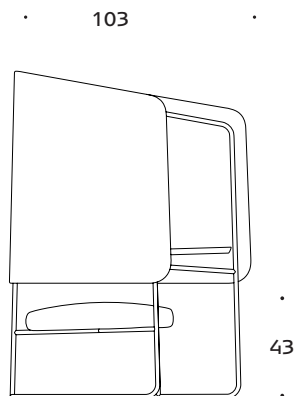
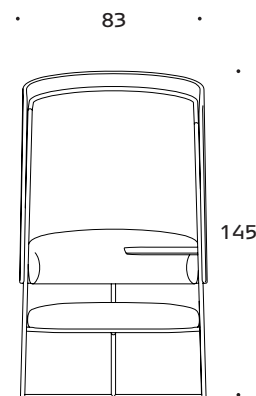



+Halle®



+Halle®



## Notes

A large grid of small dots, intended for taking notes.

## Clarity of purpose

**We believe that furniture should have clarity of purpose. This belief informs all of our work as we continue to explore and foster behavioural-led public spaces.**