

Product tear sheet

GLEE Acoustic tiles and panels

Lead time: 2-3 weeks

Origin: panel manufactured in China, NSW processing

Fire Rating: AS 5637.1:2015 group 1



GLEE range is developed to bring uncomplicated and cost-effective solution, where decorative effect is required, while offering acoustic, visual, and physical barrier properties.

9mm and 12mm post-consumer PET fibre panel is cut to shapes using precision CNC technology.

Glee is fully pinnable and is available in optimised format to reduce wastage. Kits are suitable for wall application, workstation screens, ceiling and hanging installation.

We recommend good quality web adhesive for wall application, conventional hardware will work for desktop, ceiling, or suspended installation.

Custom shapes are also available, please enquire – we love a challenge.



Product tear sheet

HOUSE RANGE WORKSTATION SCREENS
Single colour kit, full sheet usage



4 x 2
12mm

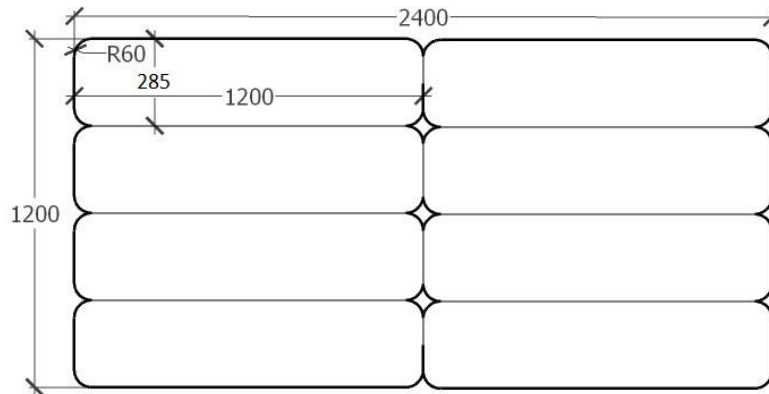

4 x 1
12mm, 24mm

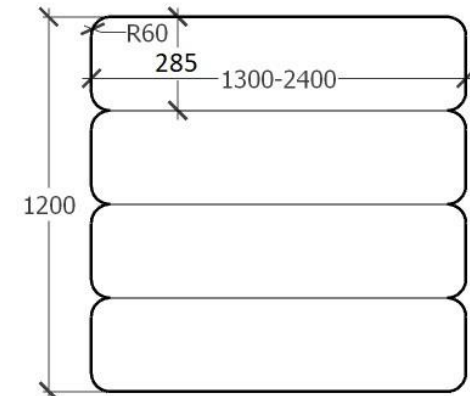

3 x 2
12mm

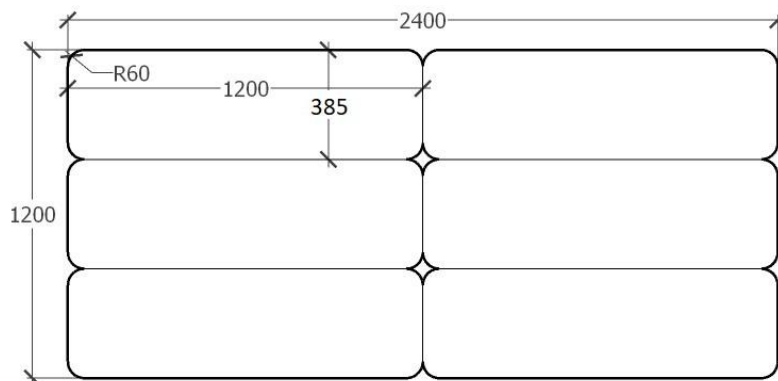

3 x 1
12mm, 24mm

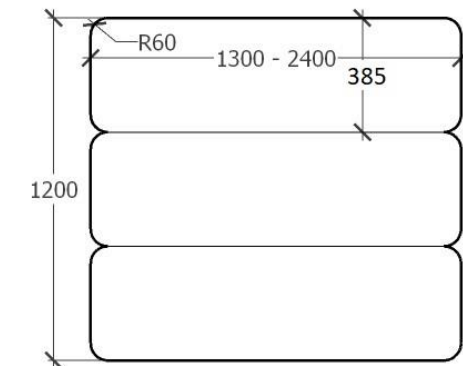

Product tear sheet

2 x 2
12mm

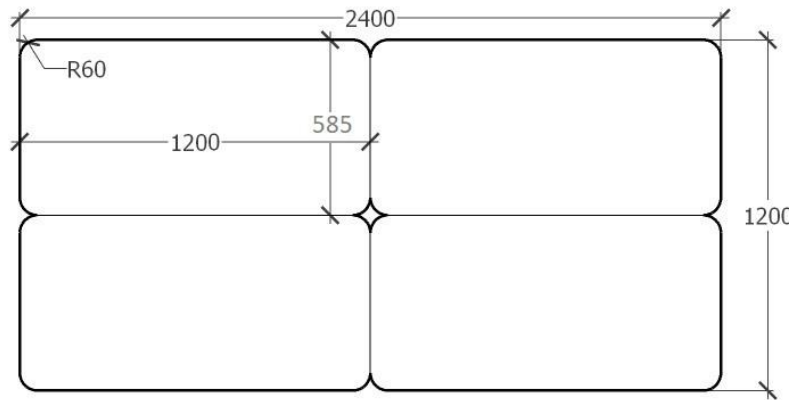

2 x 1
12mm, 24mm

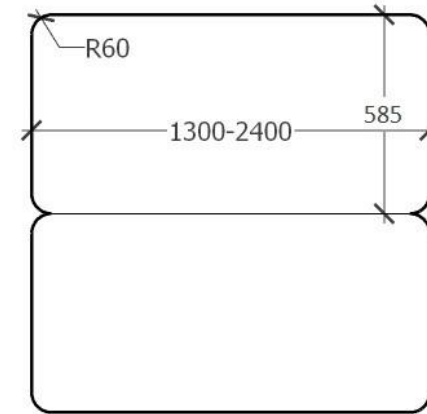

Slide on
territory
4 x circles
12mm,
24mm

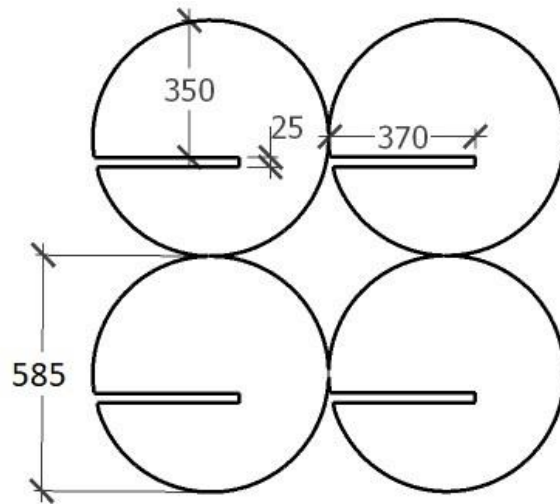

Slide on
territory
4 x rectangles
12mm, 24mm

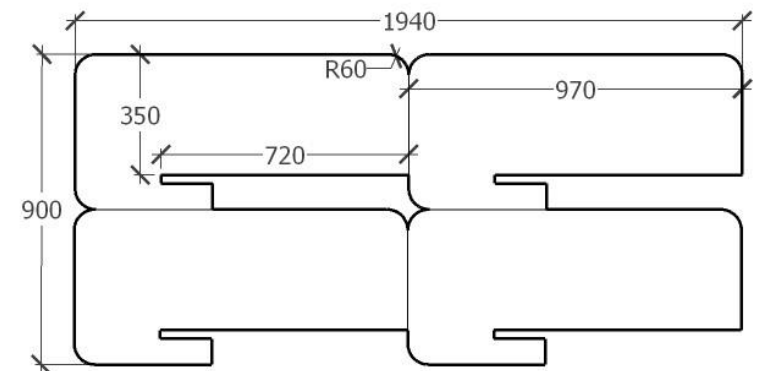

WORKSTATION SCREENS HARDWARE

GRIP

Suitable for use with 12mm to 17mm thick panel

Heavy duty tape installation to desk top surface to avoid drill holes

White or black powder coat colours in stock

MTO – Dulux or Interpon standard powder coat colour ranges

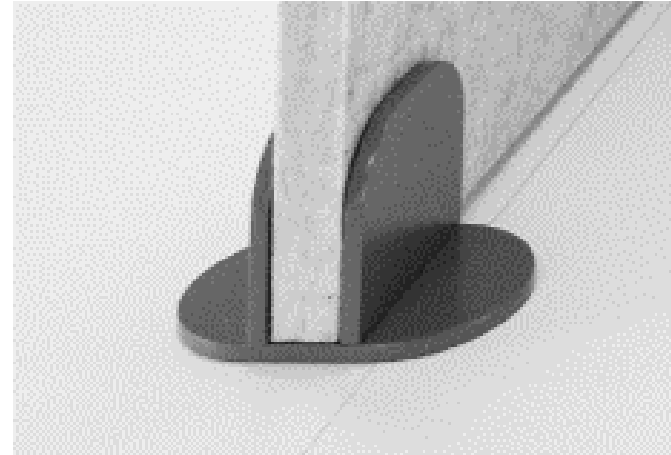
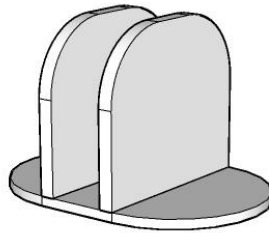

CLAMP

Suitable for use with 12mm to 17mm thick panel and 25-33mm thick desktop

no drill holes required

MTO – Dulux or Interpon standard powder coat colour ranges

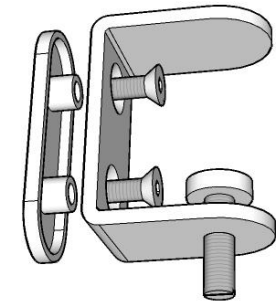

Product tear sheet

HOUSE RANGE TILES Single colour kit

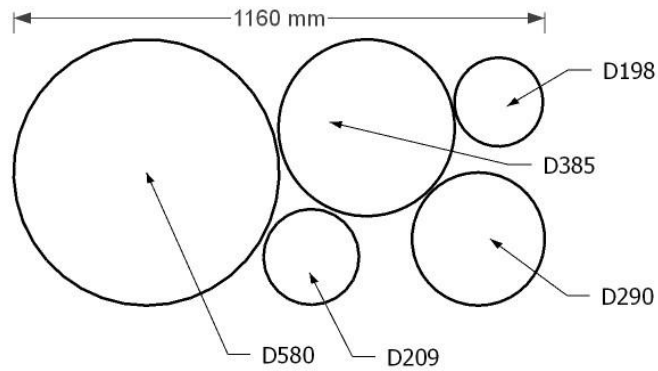
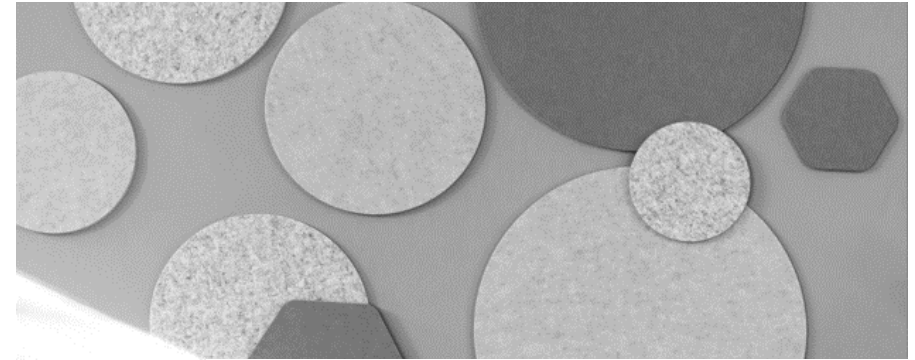

*CIRCLE
quarter sheet
usage
9, 12, 24mm*

*DONUT
half
sheet usage
9, 12, 24mm*

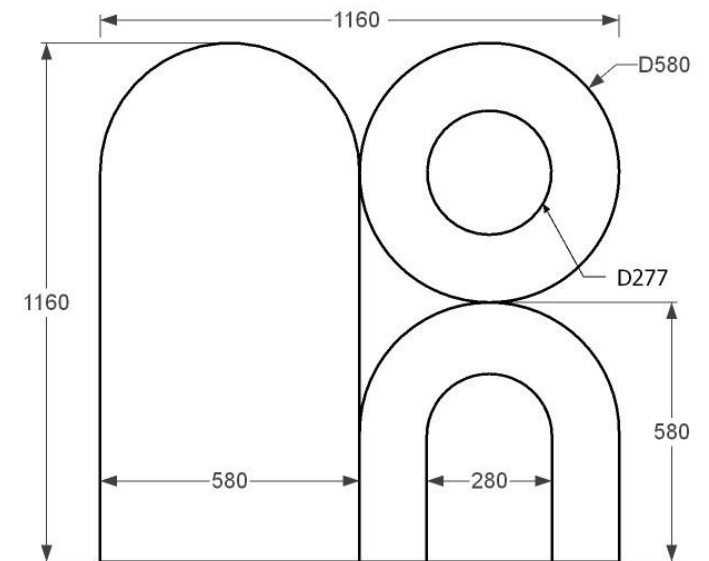

Product tear sheet

HONEY
quarter sheet
usage
9, 12, 24mm

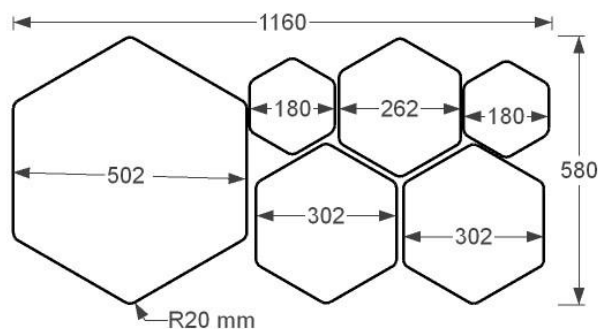

ARROWS
half sheet
usage
9, 12, 24mm

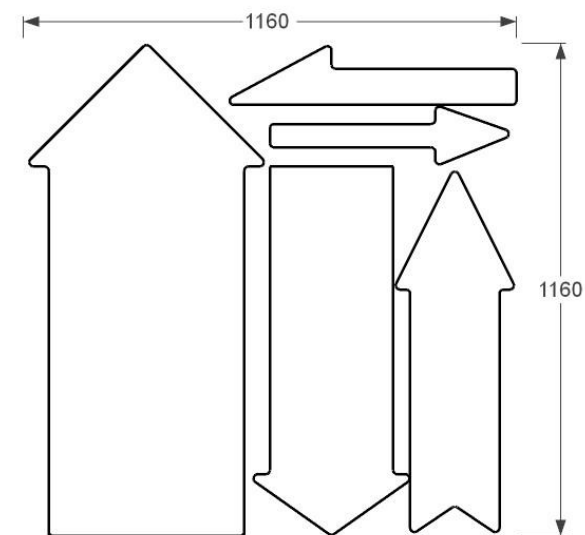

SQUARE
quarter sheet
usage
9, 12, 24mm

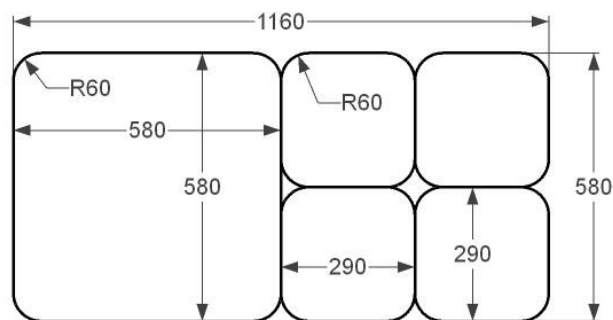

MONSTERA
half sheet
usage
9, 12mm

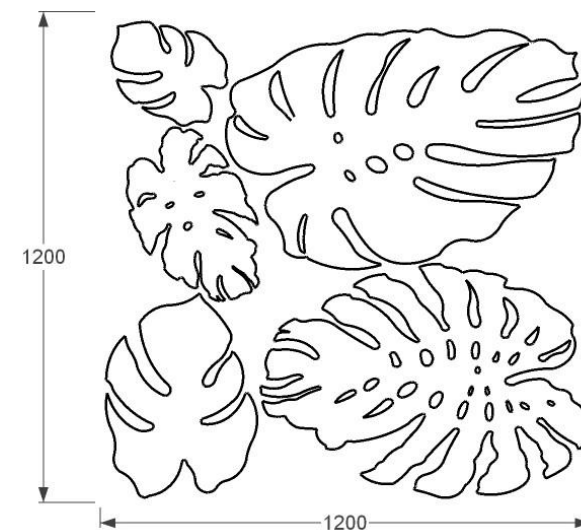

Product tear sheet

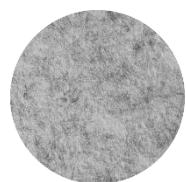

BZ11
2400x1200x9
2800x1200x12



BZ30
2400x1200x9
2800x1200x12

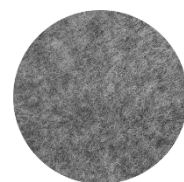

BZ36
2400x1200x9
2800x1200x12

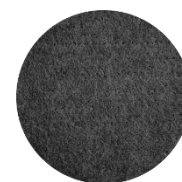

BZ37
2400x1200x9
2800x1200x12



BZ03
2800x1200x12



BZ13
2400x1200x9
2800x1200x12



BZ16
2800x1200x12



BZ04
2800x1200x12



BZ12
2400x1200x9
2800x1200x12



BZ32
2400x1200x9



BZ34
2400x1200x12



BZ28
2400x1200x12



BZ46
2400x1200x9



BZ05
2400x1200x9



BZ08
2400x1200x12



BZ24
2400x1200x9



BZ60
2400x1200x12



BZ50
2400x1200x12



BZ09
2400x1200x9



BZ25
2400x1200x12



BZ01
2400x1200x9
2800x1200x12



BZ27
2400x1200x12



BZ23
2800x1200x12

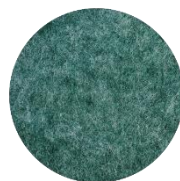

BZ10
2400x1200x9



T11
2400x1200x12



BZ51
2400x1200x9



BZ43
2400x1200x9

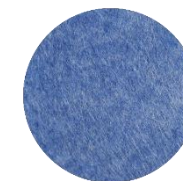

BZ14
2400x1200x12

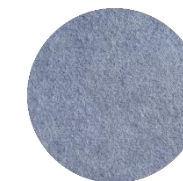

BZ47
2400x1200x9

COLOUR RANGE

All sizes shown in millimetres, colour variation of approx. 5% between batches may occur.



Product tear sheet



Flame Retardant: EN 13501

Acoustics: EN ISO 354:2003

Weight Range: 1300g/m2-3500g/m2

*Eco-friendly: AS/NZS 4266 recycled
PET staple fibre no chemical irritants
free of harmful substances*

Call: [0410528300](tel:0410528300)

Visit: [380 Princess Highway, St. Peters, NSW 2044](https://www.klarodesign.com.au)

Email: alona@klarodesign.com.au

