

# WEDGE SIMPLE

1 FIX ALL JOINERS TO ONE PANEL WITH BUTTONS. ENSURE THEY ARE VERY FIRMLY TIGHTENED USING AN ALLEN KEY. NOTE: THE ORIENTATION OF THE PANEL WITH THE BLIND HOLE BELOW THE THROUGH HOLE.

2 LAY ASSEMBLED PANEL FLAT WITH JOINERS FACING UPWARDS AND LOCATE THE SECOND PANEL ON THE SCREWS. FASTEN BUTTONS IN PLACE.

3 SCREW IN CASTOR WHEELS AND ASSEMBLY IS COMPLETE!

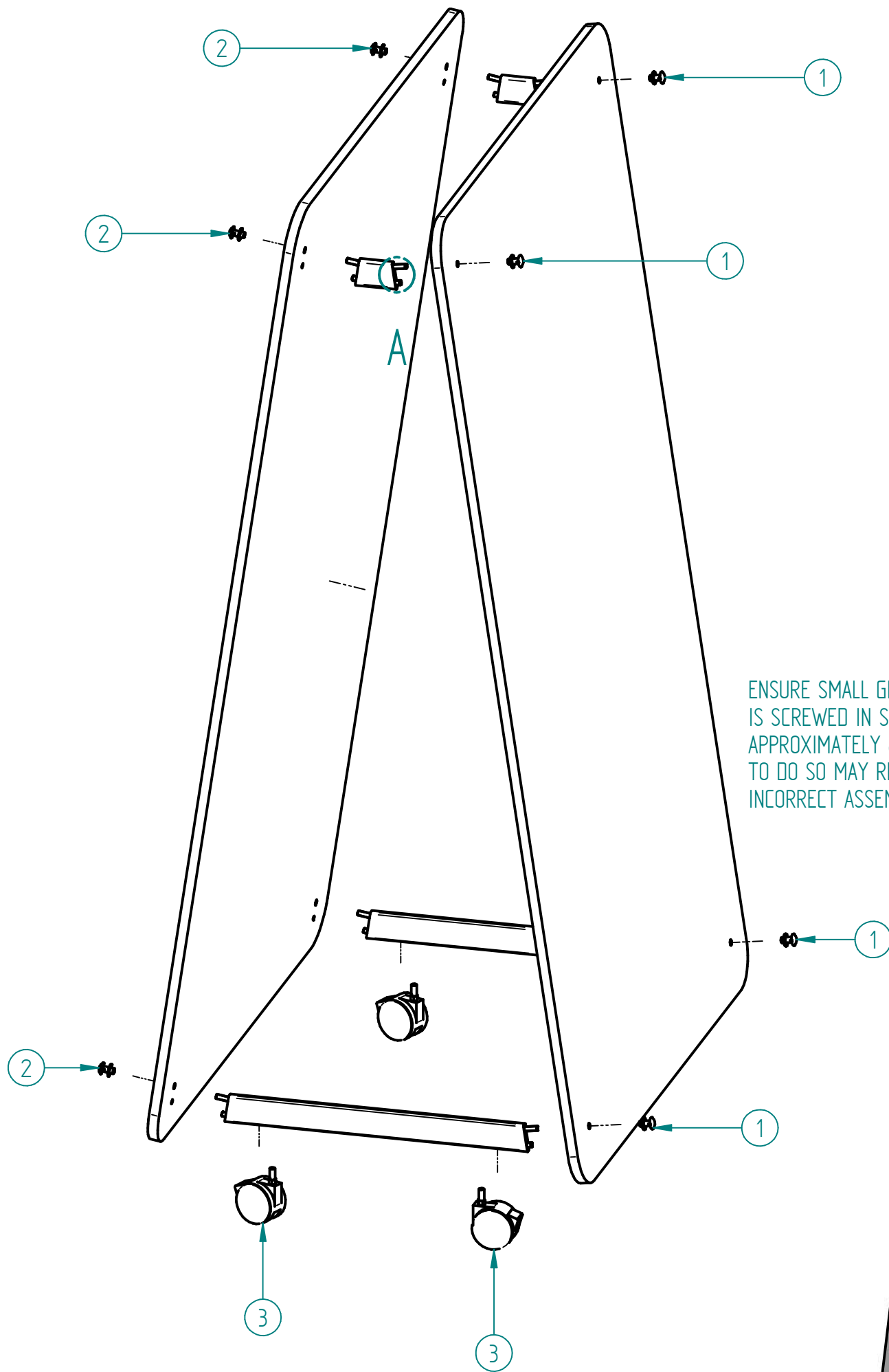

ENSURE SMALL GRUB SCREW IS SCREWED IN SO IT PROTRUDES APPROXIMATELY 8MM - FAILURE TO DO SO MAY RESULT IN INCORRECT ASSEMBLY

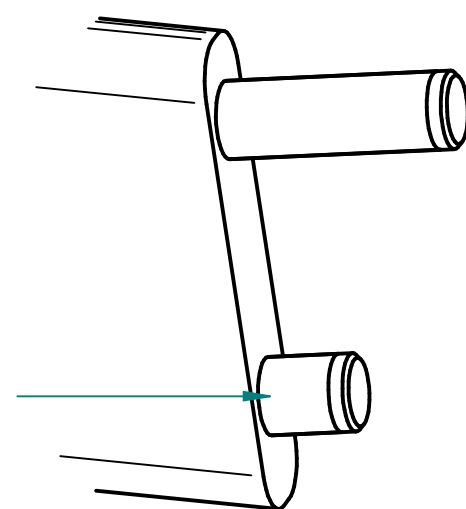

DETAIL A

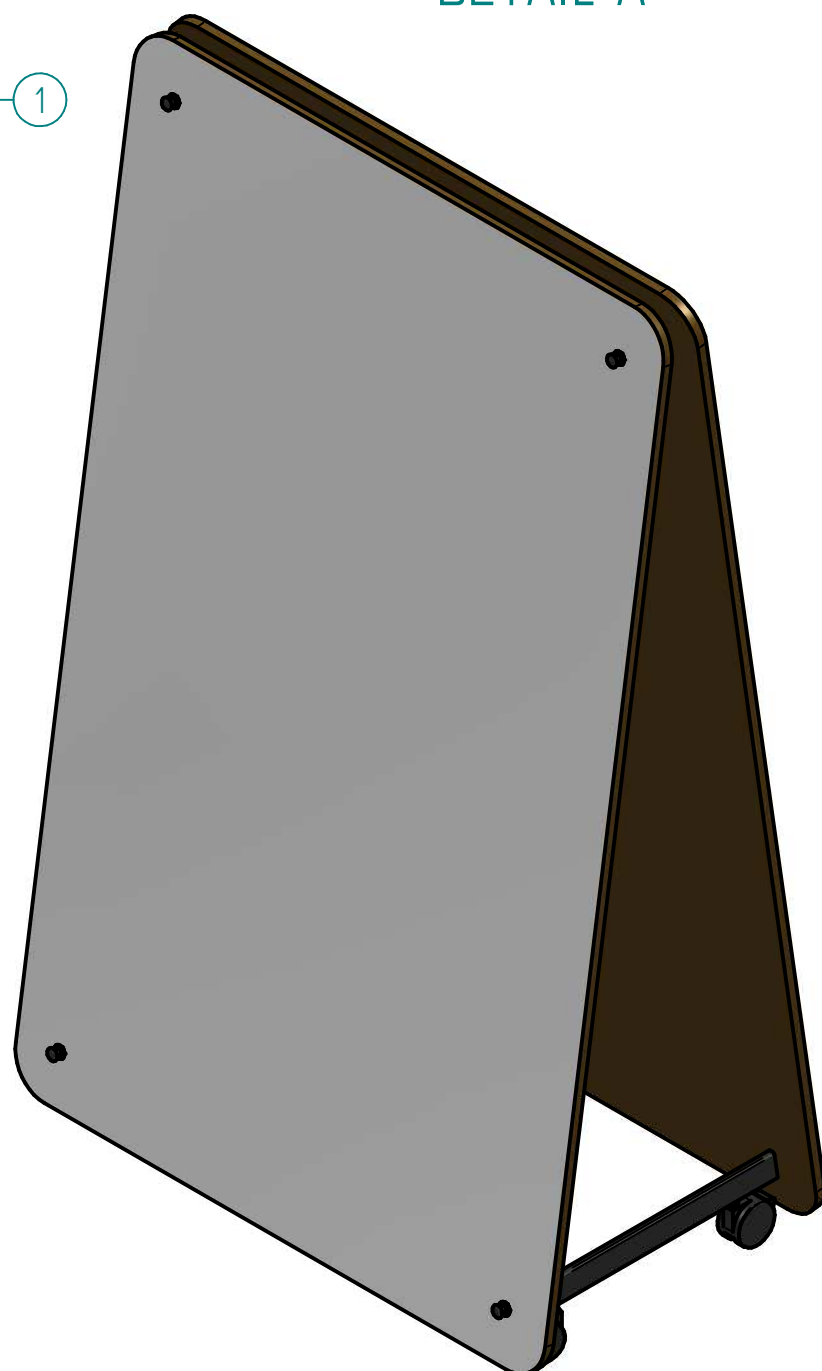

luxxbox Pty Ltd  
 43 Kenyon St, Qld 4009 Australia  
 p+61 (0)7 3257 2822  
 f+61 (0)7 3257 2844  
[www.luxxbox.com](http://www.luxxbox.com)  
 copyright 2015, all rights reserved.  
 Designs are the property of  
 Luxxbox Pty Ltd and can not be  
 used or reproduced without  
 expressed written permission.  
 abn 59123193788