

AgileMotion Electric Desk.

Product **Specifications**



Innovative Thinking • Responsive Support • Open Communication

myolg.online

AgileMotion Electric Desk.

AgileMotion is a fully optioned electric height programmable desking system, designed for modern, premium office spaces. The system also integrates seamlessly with the single workstations and back to back desks, and can be further enhanced with fabric privacy panels, floor mounted Studio50 or AcoustiQ screens, monitor arms and personal storage units.

Available in single sided, double sided, 90° and 120° designs, the AgileMotion electric desking system can be fitted with a variety of cable management options and multiple accessories...

Key Features

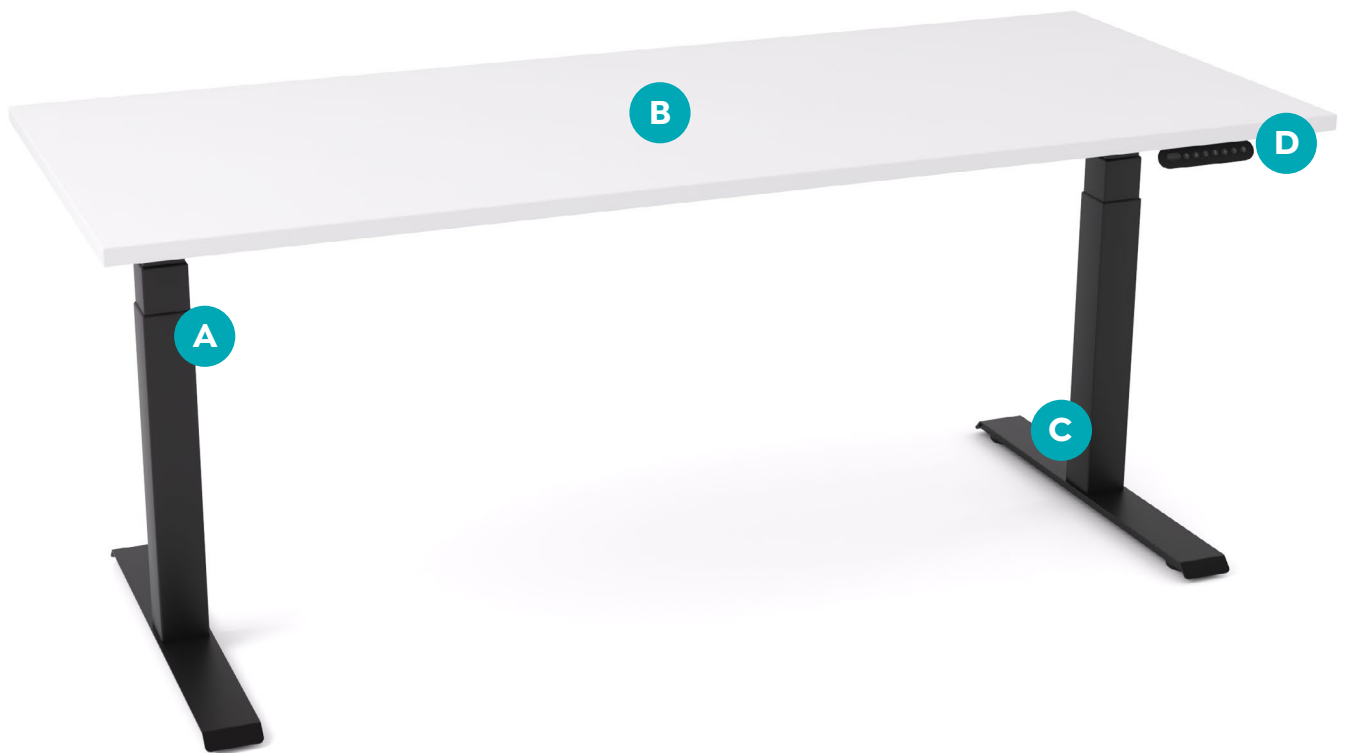

A. Height Adjustment

3 x Column height adjustment from sitting height - 620mm to full standing height - 1270mm.

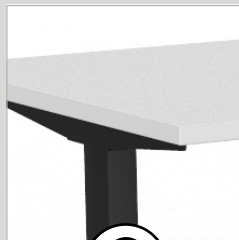

B. E0 Grade Worktop

Commercial grade 25mm melamine worktop constructed with zero formaldehyde.

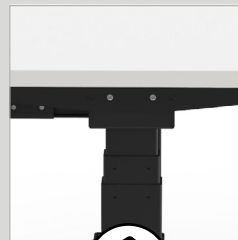

C. Strong & Durable

Frame is constructed from 2mm Steel for extra strength and stability.

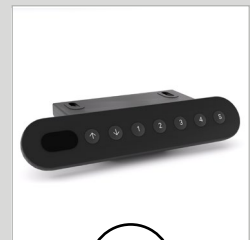

D. Electronic Handset

LED display handset with 4 x programmable memory presets.



AgileMotion Electric Desk.

In Detail



Fast Assembly

Fast to assemble - rails come pre-fitted to the legs where possible.



Anti-Collision

Protect your office equipment against damage with the built-in anti-collision software.



Quiet Motor Operation

Motors are concealed in each leg resulting in whisper quiet operation.



Strong Mechanism

Electric double motor and premium materials results in a weight rating of 140kg when distributed evenly.



Precision Memory

4 point memory control, programmable to restrict min/max height and also to set anti-collision sensitivity.



* Refer to page 8 for Ratings & Certifications details.

AgileMotion Electric Desk.

Optional Upgrades



AgileMotion Single Sided Desk
Black Frame with New Oak Worktop
White frame also available



AgileMotion Double Sided Desk
Black Frame with New Oak Worktop
White fFrame & Worktop also available



AgileMotion Single Sided Desk White Frame
& Worktop with Cable Management
Tray and Studio50 Hung Screen
AcustiQ Screens also available



AgileMotion 90° Single Sided Desk
White Frame with New Oak Worktop
Black frame also available

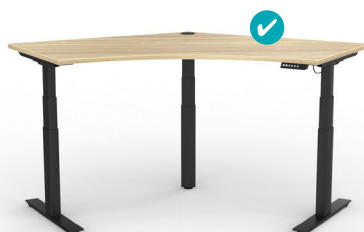

AgileMotion 120° Single Sided Desk
Black Frame with New Oak Worktop
White frame also available

Mellamine Worktop Colour Options



New Oak



White

Steel Frame Colour Options



Black



White



Studio50
Screens are
Australian
Made.

Breathe

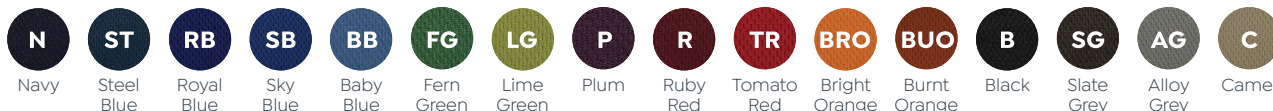

Splice



AcustiQ Screen Colour Options



AgileMotion Electric Desk.

Dimension Specifications

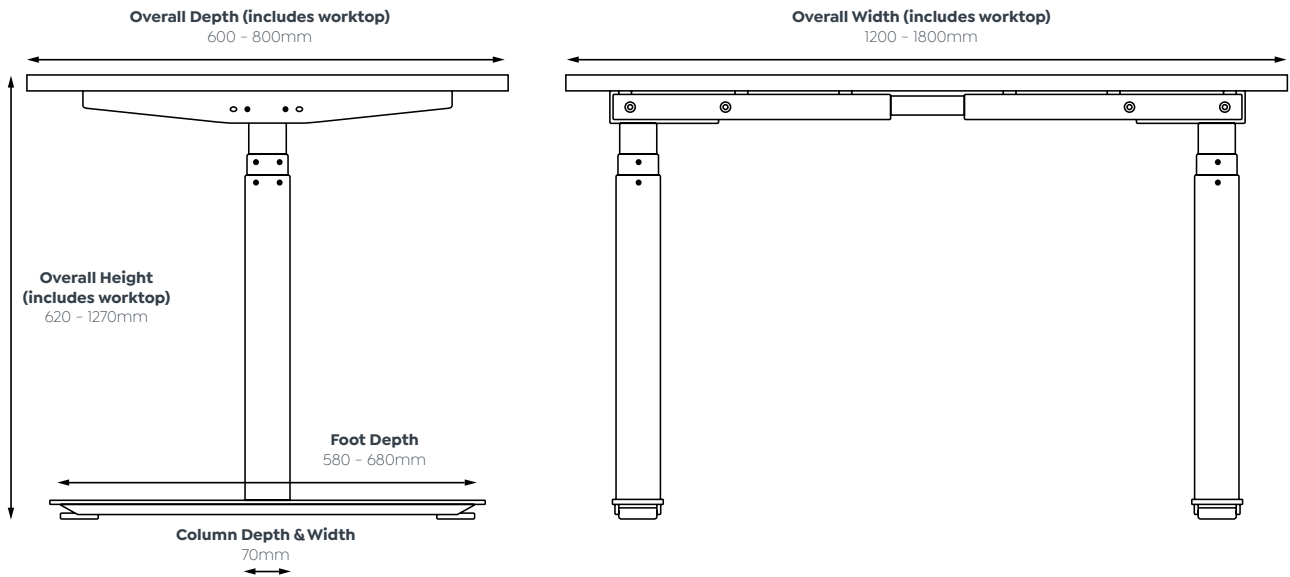

Screen Dimensions

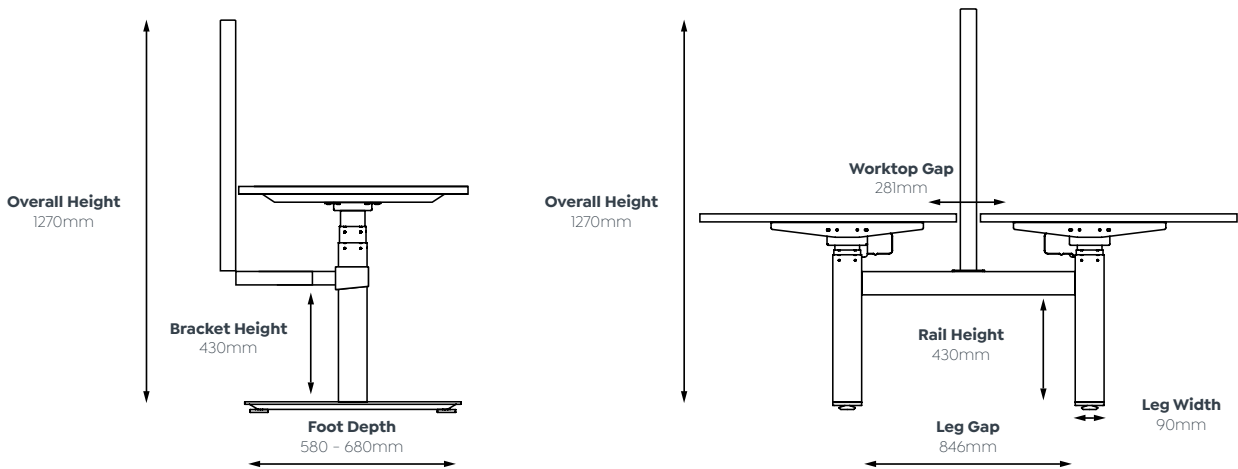

90° & 120° Dimensions

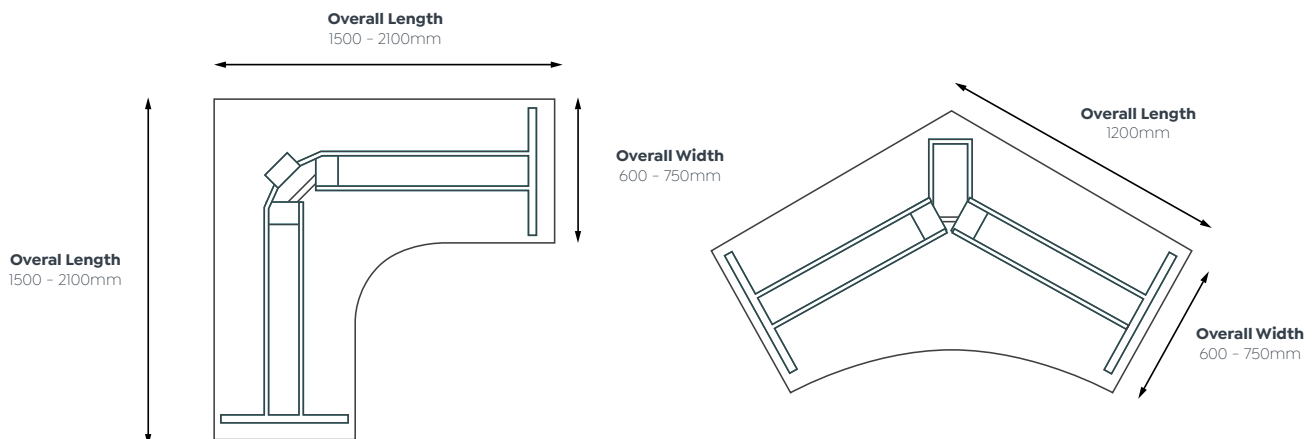

AgileMotion Electric Desk.

Workstation Configurations

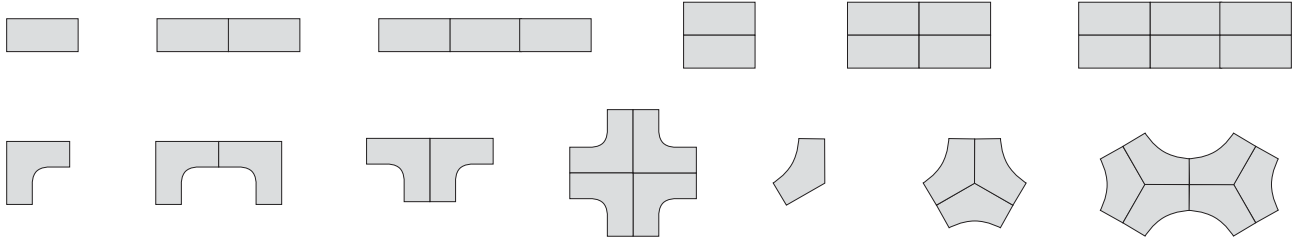

Available Sizes

Single Sided

1200 x 600mm	1200 x 750mm	1500 x 800mm
1500 x 600mm	1500 x 750mm	1800 x 800mm
1600 x 600mm	1600 x 750mm	
1800 x 600mm	1800 x 750mm	

Double Sided

2 x 1200 x 600mm	2 x 1200 x 750mm	2 x 1500 x 800mm
2 x 1500 x 600mm	2 x 1500 x 750mm	2 x 1800 x 800mm
2 x 1600 x 600mm	2 x 1600 x 750mm	
2 x 1800 x 600mm	2 x 1800 x 750mm	

Single 90°

1800 x 1800 x 600mm
1800 x 1800 x 750mm

Single 120°

1200 x 1200 x 600mm
1200 x 1200 x 750mm

OLG's Ratings & Certifications.



10 Year Warranty

OLG Warranty promises the original purchaser that it will repair or replace with comparable product, at its option and free of charge (for material and components), any product, part or component which fails under normal use over the duration of the specified warranty term (taken from the date of purchase). Normal commercial usage is defined as the equivalent of a single shift, 40 hour work-week.



Weight Rating

All seating products have an OLG endorsed 120kg minimum weight rating. All OLG seating products are designed with reference to relevant international standards, including ANSI/BIFMA and AS/NZS. These standards stipulate strength & durability requirements and give the user confidence about the product's longevity. OLG's ISO certified factories use propriety test rigs to issue OLG's own weight ratings for chairs.



ISO 14001

ISO 14001 Certification is the international standard that specifies requirements for an effective Environmental Management System (EMS). It provides a framework that OLG as an organization can follow. At OLG we are using this framework as an approach to continuous improvement across all environmental aspects of our business.



ISO 9001

ISO 9001 Certification is the world's most widely recognized Quality Management System (QMS). At OLG its our guiding principle to meet the expectations and needs of our customers through quality management systems that continually monitor and manage quality across all operations to deliver consistent performance and service.



AS/NZS 4801

AS/NZS 4801 is the benchmark to assess Occupational Health & Safety Management systems for organisations. This standard contains vital information about meeting legal requirements and invaluable guidance on how to establish sustained improvement in health and safety performance in your business.



GECA Certification

GECA (The Good Environmental Choice Australia) Ecolabelling Program, operates a national third-party, independently verified ecolabel, in conformance with Environmental labels and declarations (ISO 14024), that can be applied to a wide range of products and services. This certification gives you an independent, reliable and convenient way to select OLG products and services that are certified by GECA to deliver better environmental outcomes. Anvil and Axis (available to GECA specification by special request). EkoSystem approved as EKO Brand.



AFRIDI Certification

AFRDI Certification is a set of standards covering strength, durability, stability and safety (and ergonomics in the case of desks and workstations). This means that OLG are accountable for maintaining the quality of our products, submitting them for regular auditing to ensure they meet the highest standards for commercial use. Applies to: Urban Mesh (Level 6 – Severe Commercial), Modulus Flip Table (Level 3 – Severe Commercial, tested with 1500 x 750 top and Agile+ Single Sided Dual Motor Electric Desk).



BIFMA Certification

BIFMA Certification focuses on safety and performance standards developed by the BIFMA Engineering Committee. The standards provide manufacturers, specifiers, and users with a common basis for evaluating safety, durability, and the structural adequacy of the specified furniture, independent of construction materials. The standards define specific tests, laboratory equipment to be used, the conditions of test, and the minimum acceptance levels to be used in evaluating these products. Applies to: Balance Executive, Balance Task, Optic Chair, Adapta Chair, Game Chair 4 leg, Game Chair 4 leg with seat and back pads, Game Sled, Game Sled with seat and back pads, Agile+, Agile Electric 2-Column single motor, Motion Sync



Australian Trusted Trader

Australian Trusted Trader Certification is a standard that rewards companies showing compliant behaviour, secure supply chain with strong security practices, to enjoy a wide range of trade facilitation benefits. OLG have held this status since 2017.



FSC

FSC is the leading catalyst and defining force for improved forest management and market transformation, shifting the global forest trend toward sustainable use, conservation, restoration, and respect for all. Applies to: Plantation timber legs



GREENGUARD Certification

A GREENGUARD Certification ensures that a product has met some of the world's most rigorous and comprehensive standards for low emissions of volatile organic compounds (VOCs) into indoor air. GREENGUARD Gold Certification offers certification criteria that considers safety factors to account for sensitive individuals (such as children and the elderly), and ensures that a product is acceptable for use in environments such as schools and healthcare facilities.

AgileMotion Electric Desk.

Cheat Sheet Quick Guide

Standard Features

- 70 x 70mm legs
- Frames finished in white or black powdercoat
- H frame design - double sided desk
- Concealed motors in each leg
- Commercial-grade 25 mm worktops are constructed from E0 board and finished in white melamine with matching 2 mm
- Electric Double motor height range- 620-1270mm. Adjustment speed 30 mm/s
- 140 kg weight rating (evenly distributed)
- 4 point memory control with LCD readout, programmable to restrict min/max height and to set anti-collision sensitivity.
- Fast to assemble - rails come pre-fitted to the legs where possible
- 10 year warranty - best in its class

Optional Upgrades

- 50mm Studio screens
- 50mm Studio screens with intergrated cable duct
- 10, 20 & 30mm AcoustiQ screens
- Cable trays - system includes desk to desk bridges, power/data mounting points (inside the tray or on the vertical face) and cable snakes to the desktop

Available in

- Single - Desk
- Single - Workstation
- Shared - Back to Back
- 90° - Workstation
- 120° - Workstation



Upgrade Options

- Double Sided Workstation
- 90° Workstation
- 120° Workstation
- Cable Management Solutions
- Multiple Screen Options Available

Mellamine Worktop Colour Options



Steel Frame Colour Options



Breathe



Splice



AcoustiQ Screen Colour Options





AgileMotion double sided desking with Engage seating, Profi x monitor arms and Acoustiq screens.

Additional Options.

Storage



Axis Mobile Drawers
Two Box Drawers + One File Drawer - Gang Locking



Axis Mobile Drawers
Four Box Drawers Gang Locking



Axis Caddy Mobile Bookcase
2 x Adjustable Shelves



Axis Caddy Mobile Bookcase
1 x Drawer Insert
Left or Right Handed Configuration



Axis Caddy Mobile
2 x Drawer Insert



Axis Caddy Mobile Bookcase
1 x Tambour Insert
Left or Right Handed Configuration



Axis Caddy Mobile Bookcase
1 x Tambour Insert
1 x Drawer Insert
Left or Right Handed Configuration



Axis Caddy Mobile
2 x Tambour Insert



Agile Steel Caddy L/H
Metal caddy unit with tambour and 3 drawers. Available in 2 Powdercoats



Agile Steel Caddy R/H
Metal caddy unit with tambour and 3 drawers. Available in 2 Powdercoats



Agile Regular Steel Mobile
Metal mobile drawer unit with 2 drawers and 1 file. Available in 2 Powdercoats



Agile Narrow Steel Mobile
Metal mobile drawer unit with 2 drawers and 1 file. Available in 2 Powdercoats



Axis Credenza 1200 Two Levels
2 x 25 mm adjustable shelves



Axis Credenza 1800 Two Levels
1 x 18 mm adjustable shelves
4x hinged locking doors



Axis Bookshelf Three Levels
2 x 25 mm adjustable shelves



Axis Bookshelf Five Levels
3 x 25 mm adjustable shelves
1 x fixed shelf



Axis Cupboard Locking Three Levels
2 x 18mm adjustable shelves



Axis Cupboard Locking Five Levels
3 x 18 mm adjustable shelves
1 x fixed shelf



Axis Tower Bookcase
2 x Adjustable Shelves



Axis Tower Bookcase
1 x Drawer Insert

Accessories



Monitor Arms
Axis / Studio50 Brackets



Cable Management
Above Desk / Below Desk



Modesties
Melamine / Metal



Laptop Riser
Available in Black



Deskmount Shelves
Studio White
243 high x 600 wide x 300 deep



We'd love to help.

02 8188 2732

info@olgoffice.com

myolg.online

olgoffice.com

officedesigner.net

motionoffice.com

officefitoutcalculator.com.au

myolgpricelist.online

acoustiq.com.au

Innovative Thinking • Responsive Support • Open Communication