

Product tear sheet

COLUMN h/a exec

Height adjustable desk base system with credenza return

Motor: dual, smooth, low noise operation

Control pad: USB charging module, digital display with 4 memory functions and timer option.

Safety considerations: up and down anti-collision settings to 8 sensitivity levels. Low- and high-level limit pre-set or locked height option. Overheating protection.

Storage: Laminex or Polytec 18mm melamine construction, soft close doors and drawers with finger pull detail and inclusion of services reticulation

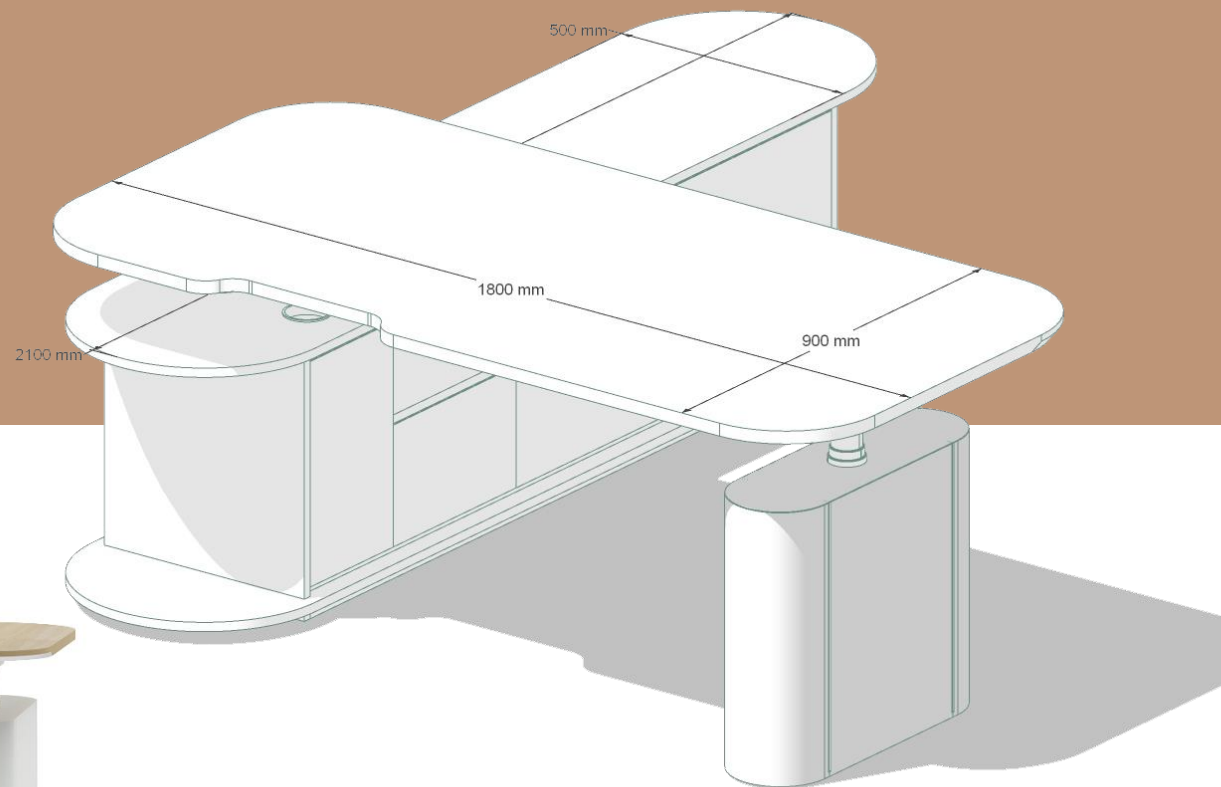

Product tear sheet

Configuration: L shape desk

Height range: 640-1290mm

Top width: 1400-2100mm with 1800 – 2400mm long return credenza at 534mmH

Speed: 38mm/s

Load capacity: 120kg

Lead time: 4-6 weeks

Origin: China – all steel parts, Australia – all melamine parts

Base finish: Black or white satin powder coat actuators, with custom colour options available to the shroud. Credenza – Laminex, Polytec melamine board or to client specification

Top finish: to client specification

Screen/modesty panel finish: 24mm or 12mm thick PET panel or PUFFY screen

Cable management

TRAX_lite

Finish:

White, black or paperbark powder coat with custom colour options available to steel components

Charcoal, light grey or natural colour 3mm thick PET felt sling

Excludes soft-wiring components

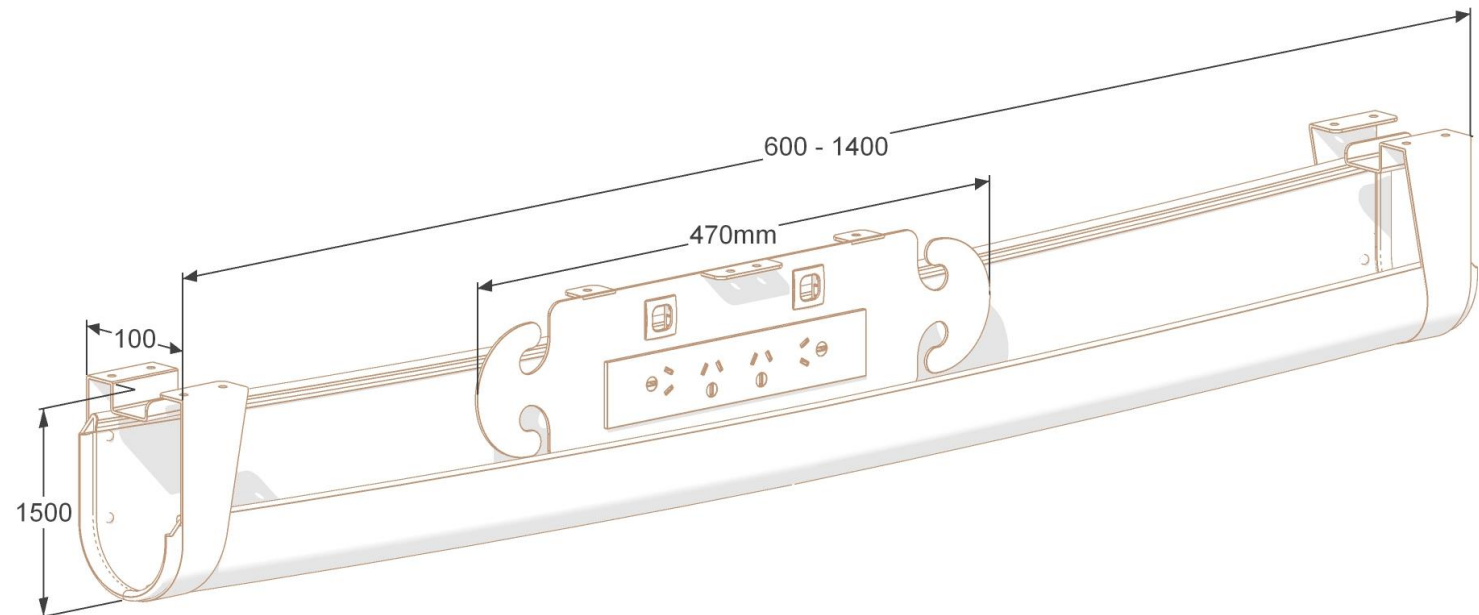

Call: [0410528300](tel:0410528300)

Visit: [shop 2, 263 Enmore Rd, Enmore, NSW 2044](#)

Email: alona@klarodesign.com.au



Product tear sheet

