

# Product tear sheet

## CONUS XL h/a table

Height adjustable table base with heavy duty lifting capacity

**Motor:** quad motor, smooth, low noise operation

**Control pad:** USB charging module, digital display with 3 memory functions and timer option.

**Safety considerations:** up and down anti-collision settings to 8 sensitivity levels.

Low- and high-level limit pre-set or locked height option.

Overheating protection.

**Configuration:** double base only

**Height range:** 640-1290mm

**Speed:** 38mm/s

**Load capacity:** 240kg

**Lead time:** 12 weeks

**Origin:** China

**Base finish:** Black or white satin powder coat, with custom color options available to shrouds

**Top finish:** to client specification

**Power box:** size restrictions apply,  
<https://www.oeelsafe.com.au/arc-g/>  
recommended option

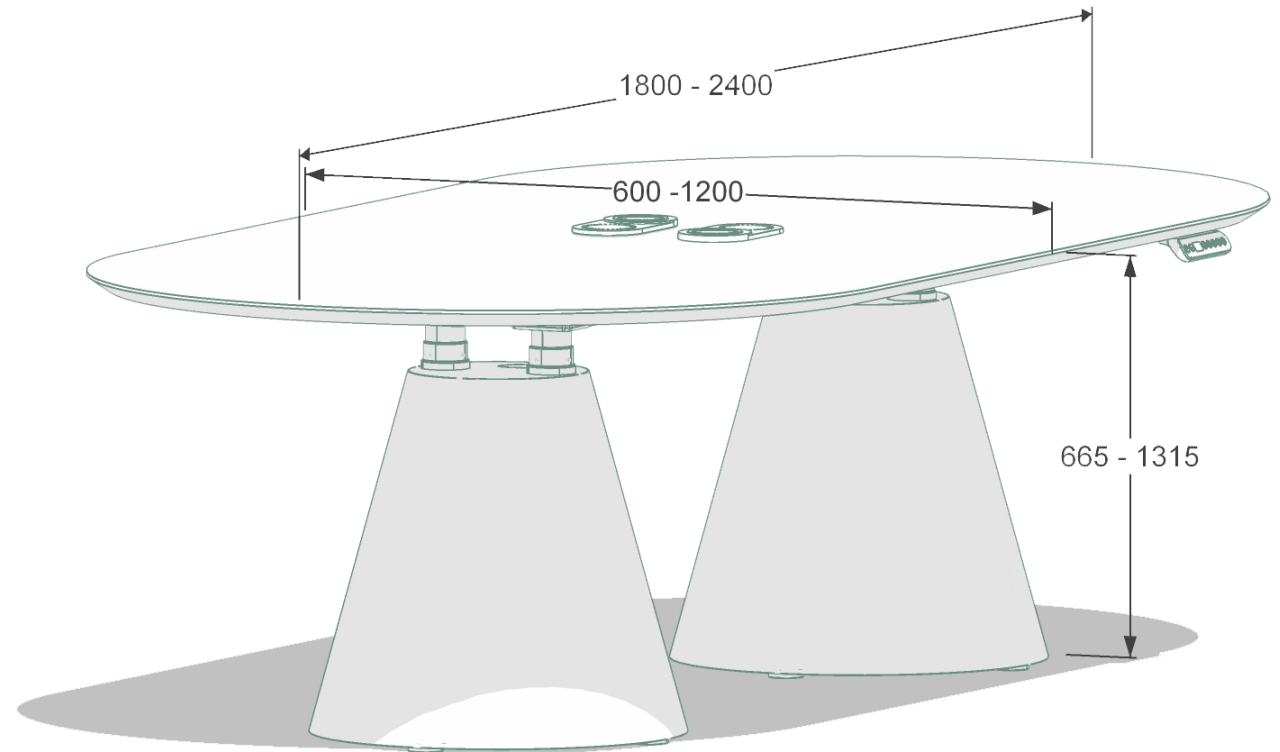

# Product tear sheet

